

FNAME: OSSIM-TP-(3001-3009)-OR

REVDATE:0520

REVISIONS				
ZONE	REV	DESCRIPTION	DATE	APPROVED
	A	DUAL FLOAT SWITCH UPDATE	7/17/16	
	B	RELOCATION OF POWER ON LIGHT WIRING	12/15/16	
	C	OIL SMART SWITCH UPDATE	11/06/17	
	D	UPDATED XF1	5/21/20	JED

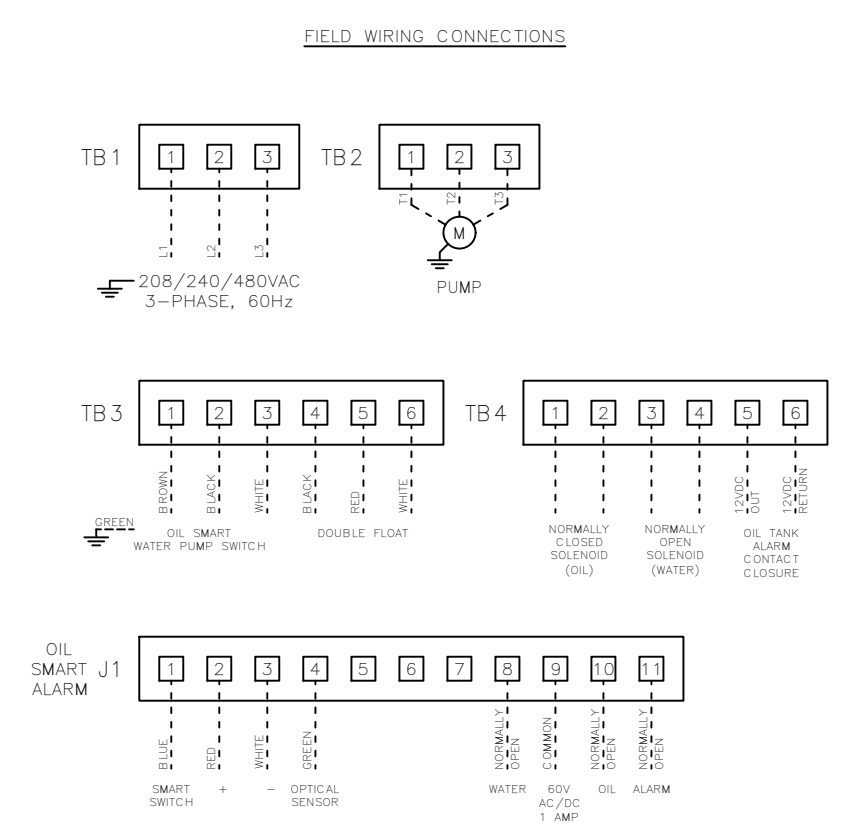
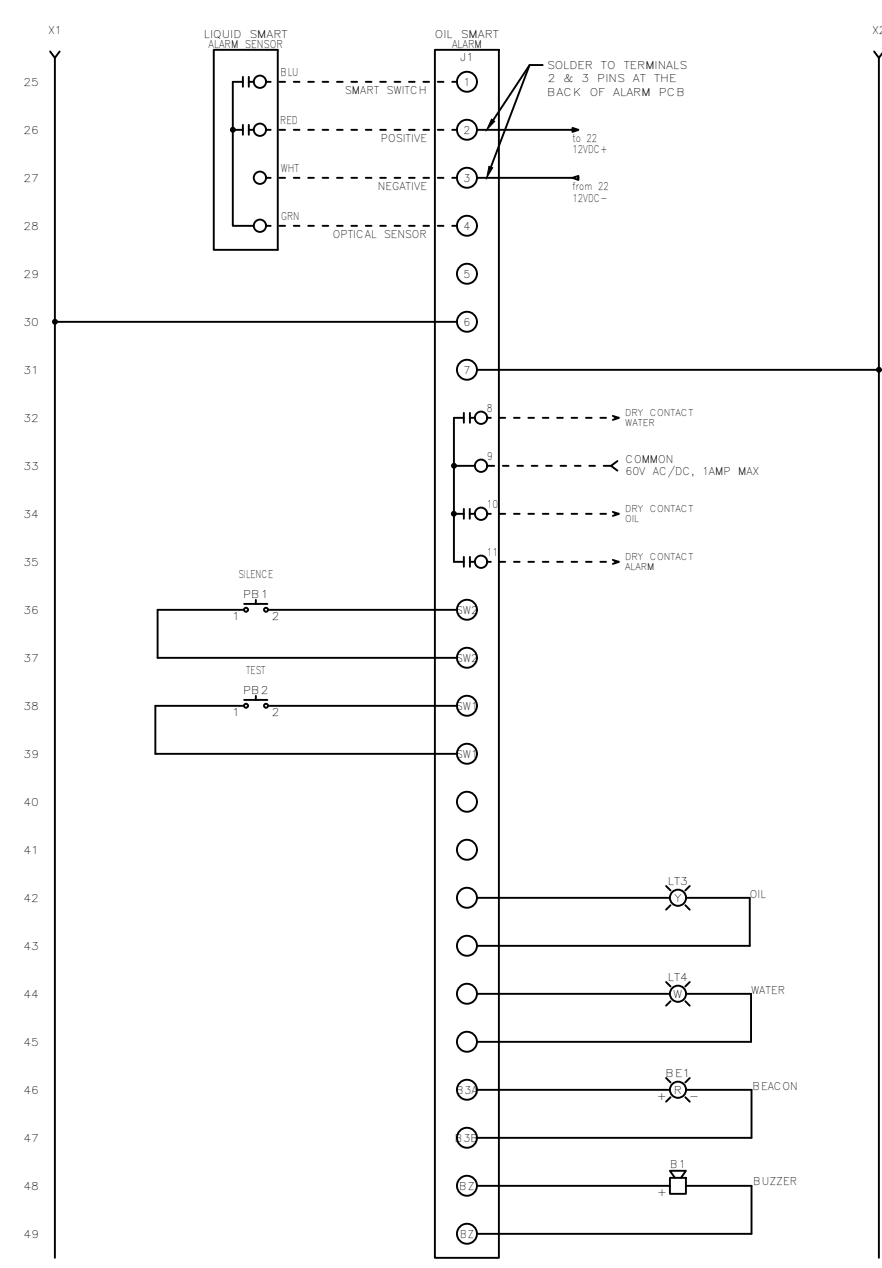
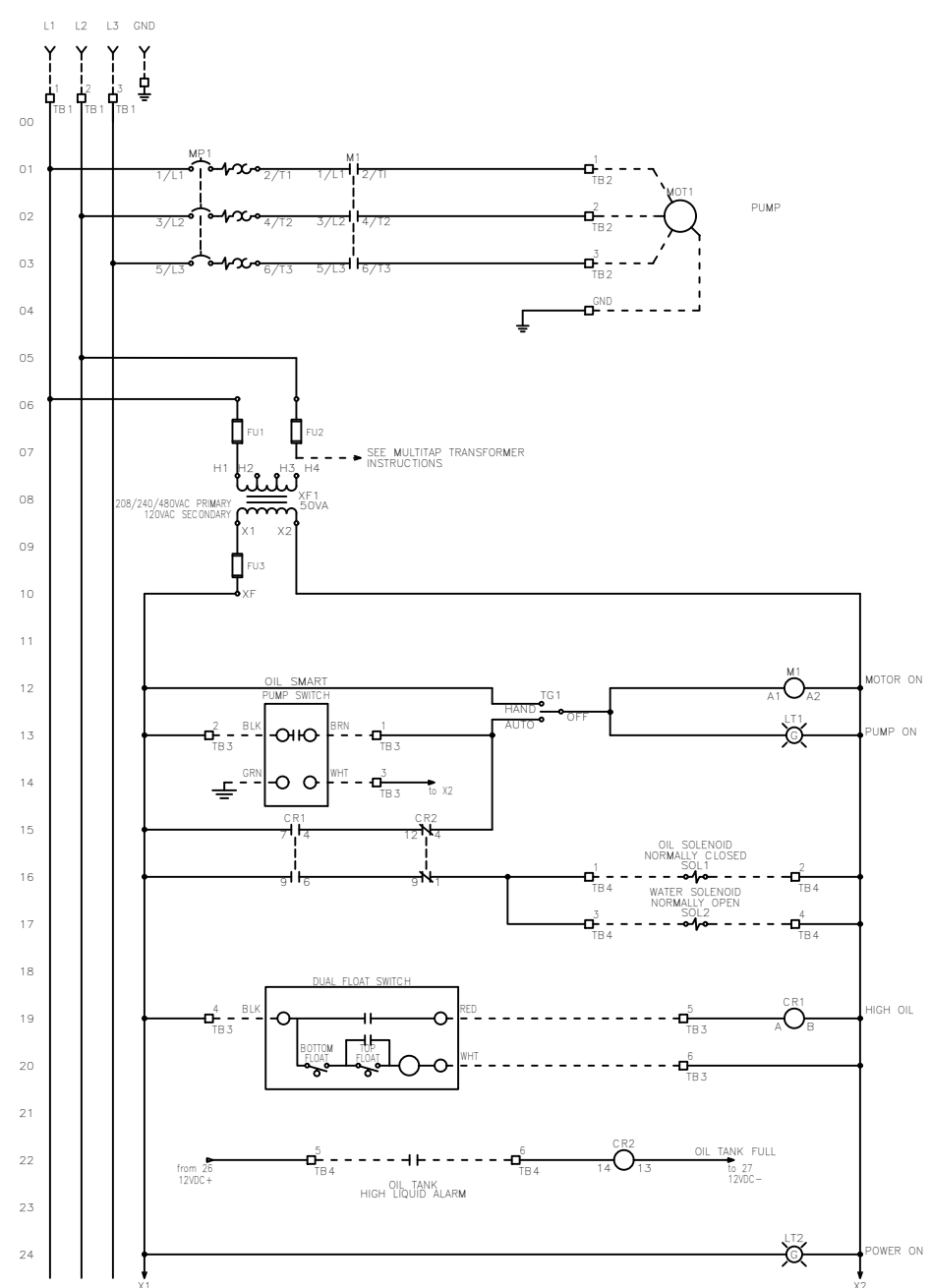

MULTI-TAP TRANSFORMER:
 CONNECT FACTORY TAGGED WIRES TO APPROPRIATE TRANSFORMER VOLTAGE TAP. SEE BELOW FOR CONNECTIONS:
 FOR 208V OPERATION, CONNECT TO FUSE INPUT HF & TO TRANSFORMER TAP H2.
 FOR 240V OPERATION, CONNECT TO FUSE INPUT HF & TO TRANSFORMER TAP H3.
 FOR 480V OPERATION, CONNECT TO FUSE INPUT HF & TO TRANSFORMER TAP H4.

----- DASHED LINE INDICATES FIELD WIRING.
 USE COPPER CONDUCTORS ONLY.
 TEMPERATURE RATING OF CONDUCTORS IS TO BE:
 60°C (140°F) FOR UNDER 100A.
 75°C (167°F) FOR OVER 100A.
 BRANCH CIRCUIT PROTECTION SHALL BE PROVIDED BY THE INSTALLER: MUST BE SIZED ACCORDING TO PUMP/MOTOR MANUFACTURING SPECIFICATIONS.
 VERIFY CORRECT OPERATION OF CONTROL PANEL AFTER INSTALLATION IS COMPLETE.

FIELD WIRING TORQUE SPECS.	
TERMINAL BLOCK UT 2,5	5 IN-LB
TERMINAL BLOCK UT 4	7 IN-LB
TERMINAL BLOCK UT 6	15 IN-LB
TERMINAL BLOCK UT 10	15 IN-LB
TERMINAL BLOCK UT 16	25 IN-LB
TERMINAL BLOCK UT 35	30 IN-LB
TS1, TS2, J2 & J3 PCB	5 IN-LB
TRANSFORMER H1F, H2F & H3F	15 IN-LB
TRANSFORMER H1, H2 & H3	10 IN-LB
DS1 VLS3P16-63 R1	16 IN-LB
DS1 VLS3P63-125 R2	45 IN-LB
DS1 LK4JU3CN 100A	36 IN-LB
DS1 LK4MU3N 200A	200 IN-LB

DRAWN BY: MM DATE: 12/11/15
 APPROVED BY: KM DATE: 12/11/15

THIS DRAWING CONTAINS PROPRIETARY INFORMATION AND SHALL NOT BE USED OR DISCLOSED WITHOUT PRIOR WRITTEN AUTHORIZATION.



TITLE: OSSIM-TP-(3001-3009)-OR CONTROL SCHEMATIC			
SIZE: B	DWG NO.: 1572	PART NO.: OSSIM-TP-(3001-3009)-OR	REV: D
SCALE: NONE		SHEET: 1 OF 1	